



Filters



Hydraulic Products

- Supply
- Manufacture
- Service
- Repair



A Virginia Corporation since 1979, ServoCon's modern laboratory facilities are located in the heart of the beautiful Shenandoah Valley. A Virginia Corporation since 1989, ALPHA engineering design, production and new parts distribution facilities have teamed up with ServoCon to provide all of your fluid power controls, sales new from ALPHA and service from ServoCon.

For two decades ServoCon and ALPHA engineers , technicians, sales and support staff have been providing the industry's highest quality sales and service in fluid power components.

**WE OFFER NEW
COMPONENTS FOR ANY APPLICATION**



**LET OUR PROFESSIONAL TECHNICAL STAFF PROVIDE YOU
WITH OVER 30 YEARS OF EXPERIENCE "WE KNOW THE DE-
SIGNS OF THE QUALITY COMPONENTS BECAUSE WE HAVE
BEEN REPAIRING THEM ALL FOR YEARS"**



QUICK TURNAROUND

The text and images contained within are © 1989 - 2005 (all rights reserved) by ServoCon Associates Inc. and ALPHA Development Bureau, Inc
167 Expo Road Fishersville, Virginia 22939 Phone: (540) 337-4900 FAX: (540) 337-4901

To Order Call: 1.800.447.7747

Table of Contents

Table of Contents	1
Filters, Manufacturers, Who We Are, What They Are	2
Filters, Where They Are Used	3
The System A Good Filter Creates	4
Filter , Particle Sizes	4
EHC System, Fluid Degradation	5
Fluid Degradation, MHC system	6
ALPHA Upgrade Information, Westinghouse EHC	7
OEM Supplied Filtration, Filtration Upgrade Summary	8
ALPHA Model Numbers Cross Reference To OEM	9
Transfer Filter Cart	10
Other Products	11
Servovalve Filters	12
Servovalve Filter Design Features	13
Turbine Control Valves	14;15
Other Products	16;17

Filters (High and Low Pressure)

Manufacturers

ABB, Abex, Advanced Filtration, Allen, ALPHA, AMF Cuno, Atchley, Bosch, Bulldog, TSI, Filpro, Foot, Flomec, Fluidtek, GE, Hepa, Hilco, Hy-Pro, Kdon, Hycon, Moog, Norman Equipment, Pall, Pall Marine, Parker, Purolator, Pnucor, Cinn Milacron, Coburn, Dowty, ETSI, Flight Safety, GE, GEMU, Honeywell, HR -Textron, Kawasaki, Koehring, MTS, Oilgear, Pegasus, Rexroth, Sundstrand, ServoCon, Ultra, VA Fluid, Vickers, WW Nugent, Westinghouse

Who We Are

ServoCon® ALPHA is a leader worldwide selling and repairing electrohydraulic servocontrols for industry using hydraulic control systems. We have certified engineers and technicians, calibrated test equipment, static and dynamic testing at the component and assembly level, large replacement parts inventory, competitive pricing and quick turn around. Our engineers and technicians have been trained by major OEMs. With over 30 years of experience, our staff can best provide for your repair or new filter needs. We are distributing and servicing most filter types and we have our own filter line to meet your needs.

What They Are

This document describes the filters used in electro-hydraulic flow control systems.

Gas and Steam Turbines, air compressors and flight simulators use hydraulics to close the loop on position, velocity (rotary and linear), and force for accurate control. Smart systems like these must have good filtration of fluid to continue operation around the clock. Steam turbine generators use these controls to regulate the amount of steam admitted to the turbine. Fluctuating demand varies the load on the turbine and the control system ensures that the rotational speed of the turbine is constant. Accuracy and quick response in this system is necessary for overall efficiency.



Filters



The control system also acts as a safety system preventing the turbine from an over-speed condition when there is a rapid reduction in load. This over-speed can cause a catastrophic failure of turbine blades thrown through the casing as a result of massive centrifugal motion. The large steam valves that control the steam flow through nozzles into these turbine blades are positioned by electro-hydraulic servocontrols. These controls are extremely sensitive to particulate contamination. Protecting these components with high efficiency fluid filtration is a requirement for smooth, dependable operation. The two most common types of control systems are Electro-hydraulic Control (EHC) and Mechanical Hydraulic Control (MHC).

FILTERS (High and Low Pressure)



Servo valves, relief valves, directional valves and solenoid operated “stop” valves are extremely sensitive to particulate contamination because of the tight operating clearances required for accurate control. Typical dynamic clearances are in the order of 1-4 micrometers for servo valves and 2-8 micrometers for fast acting solenoid valves. Silt size (1-5 micrometers) particles in the fluid enter these clearances and degrade performance through wear causing internal moving parts to stick in valve and actuator components. The result is reduced component reliability. This buildup of silt and chemical etching in the controls can cause sluggish response from the component to varying load requirements. Our Program Fluid Maintenance testing of fluid for our customers indicates that a high percentage (more than half) of solid particulate contaminants are in the 2-5 micrometer range. By installing high performance filters, the reliability of components is dramatically improved. A fluid cleanliness level of ISO 14/11 or better should be maintained. It is recommended that you use filtration elements of 75 beta ratio (10 micron absolute) to remove and control damaging particles in the fluid and preserve the required fluid cleanliness.

FILTERS (High and Low Pressure)

Electro-hydraulic Controls (EHC)

The EHC system used in modern steam turbines operates using precise electronic measuring instruments. Pilot operated servovalves in the EHC system regulate the large hydraulically operated steam control valves. Based on system feedback, these valves continuously adjust steam feed to the turbine. If the generating load is suddenly lost, solenoid operated "stop" valves actuate and instantly close the steam flow path. Fire retardant phosphate ester fluid (usually Fryquel) is used in these systems because of the closeness of the control fluid to high temperature steam. This EHC fluid reservoir is kept separate from the main turbine lube oil system. EHC system failures due to improper filtration causes the need to clean and calibrate all of the system components on a regular and systematic basis. This may be a result of using filters with media that is incompatible. It is common to experience failures due to oxidation (rust) and silting when improper filter selection is made. In many instances we have suggested the replacement of filter elements with stainless steel because they degrade or collapse under pressure when in contact with the Fryquel fluid for long periods. In Westinghouse systems we have found that the ALPHA stainless steel filters have greater dirt holding capacity while maintaining an acceptable cleanliness level and will not collapse when they are filled with silt and other contaminants. Most systems are adaptable to these filters providing optimally clean fluid.

Need For Filtration

Reliability of the control oil system depends on the hydraulic components. When a filter has a short operating life and fills up with dirt quickly, and it is because it is removing dirt as designed, then we are preventing component failure. Do not purchase filters for a long operating life as some filters manufactures advertise.

Fluid Degradation

Phosphate esters are hygroscopic (water absorbing) fluids, and can hold up to 5000 ppm water in the solution. Phosphate ester fluids react with water (hydrolyze) to produce phosphoric acid. This acid reacts with the fluid to form more acid, continuing a chain reaction of fluid quality degradation. This reaction is represented as follows:

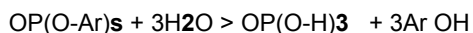

Where:

OP(O-Ar)₃ - TriAryl Phosphate

H₂O - Water

OP(O-H)₃ - Phosphoric Acid

Ar OH - Alcohol/Phenol

FILTERS (High and Low Pressure)

Fluid Degradation Continued

Phosphoric acid in fluid causes corrosion of the valves as well as erosive wear resulting from lowered fluid resistivity. The acids generated can also react with the absorbent cartridges leading to the formation of metallic salts which precipitate out of solution forming a sludge. In addition, the combination of acids and silt contribute to loss of reliability of operation due to internal parts sticking. This is usually seen as slow response and possible failure. A Fuller's Earth or Activated Alumina (absorbent) is typically furnished in an off-line re-circulating loop for acid correction. The proximity to steam and/or humidity eventually results in a water content sufficient to saturate the absorbent media, making it less effective while removing acids. The major component in the formation of phosphoric acid is water. Thus keeping the level of water to a minimum slows down acid formation. The result is higher system efficiency and actuation reliability with fewer failures due to slow response and sticking valve spools. The water content specification is that it is kept lower than 0.1% by volume. To keep a system this dry vacuum dehydration is required. Water absorption cartridges and coalescing is only partially effective in that they only remove free water from the fluid, whereas our experience has shown that dissolved water contributes significantly to the hydrolysis reaction and must be minimized. Our vacuum dehydration oil purifier is ideal for this application and can maintain water levels of 0.02% by volume in an EHC system. This will extend fluid life and provide a clean environment for the operation of critical hydraulic components.

Mechanical Hydraulic Control (MHC)

MHC systems operate using turbine lube oil from the main fluid reservoir. The system does not typically have its own filter. Rather, it relies on cleanliness measures taken to achieve clean lube oil. Those systems that include filtration use nominally rated filter elements which cannot adequately protect control valves. Since the system shares the main turbine lube oil reservoir, bearing generated contamination that is not captured by the turbine lube oil filters is carried to the MHC system and thus degrades valve performance. In order to provide maximum protection to MHC components we recommend the use of our in-line filter assembly.

FILTERS (High and Low Pressure)

ALPHA Upgrade Recommendations For EHC Systems General Electric EHC

1.) ALPHA non by-pass assemblies and high collapse rated elements may be ordered to obtain the cleanliness levels to improve reliability at the recommended level by GE of ISO 15/12 using the Alpha part numbers below:

	<u>GE</u>	<u>Pall</u>	<u>USE ALPHA</u>
Assembly	254A7229	HZ9412D24DPTSYGE	S0030002
Element	294A6678	HC9401FDP13ZAY260	S0010045
Element	294A6678	Stainless Steel (BP Tested)	S0010044

(The stainless steel element is the best for this application)

2.) Large steam turbines use a nominally rated filter downstream of a Fuller's Earth filter (or activated alumina) in a low flow (1-5 gpm) off-loop re-circulating system. Nominally rated filters are generally too coarse to prevent Fuller's Earth media from migrating to the EHC reservoir. These particles enter valve clearances and also degrade control valve reliability and performance. We recommend that these assemblies be upgraded to an ALPHA assembly using the part number below:

	<u>GE</u>	<u>PALL</u>	<u>ALPHA</u>
Fullers Activated Alumina	182A9983-2	HZ8110A16KZTBPT	S0010020

Westinghouse EHC

Westinghouse recommends that EHC fluids be maintained at an ISO code of 14/11 or better to provide a clean environment for the use of nozzle flapper servovalves. Most Westinghouse power units offer three separate filters located in the system high pressure line, low pressure return line, and as a part of an off-loop re-circulating system. These filters are manufactured by several companies who are listed under the previous manufacturers section. We have been supplying these filters to our customers as requested for years. It is recommended that these filters be upgraded to ALPHA filters for better reliability as follows: (From our historical archive)

FILTERS (High and Low Pressure)

OEM Supplied Filtration

1.) There are typically 14 Cuno (10 micron nominal) stainless steel cleanable filter elements (model 52535-02-41-0104) for each power unit. Four are usually located on top of the power unit in a manifold block. The rest are mounted under control boxes on the side of the turbine. Downstream of these is a servovalve controlling the governor controlpac valves. It should be noted that the life of filters in these units can be extended with cleaning and bubble point testing. Some filter manufacturers say that disposable elements have a longer life than the OEM elements but our experience allows us to know that the life of the element is directly dependant upon the dirt that is removed from a given system. It has little to do with whether it is disposable or cleanable. We have found that the stainless steel elements may be cleaned and used until they do not meet the bubble point test or until the units are so filled with indissoluble silt that they must be replaced. Discarding them before their useful life has ended is impractical and wasteful and many filter manufacturers will suggest using disposable units to increase sales. We have seen a degradation of system performance with the use of some disposable elements.

2.) a. There are two Schroeder model LF-8 filter housings in the return lines of the duplex hydraulic system. Each housing holds two or three 9 inch long Schroeder K3 grade (3 micron) elements (model KS-1H) stacked one on top of the other. Stacking elements provides an avenue for contaminated fluid to bypass the filter at their union.

b. Older Westinghouse turbines use Cuno model SDS nominally rated filters for return line filtration. Nine 10 inch length elements are stacked 3 high in each housing. The combination of nominal rating and stacking of elements reduces their effectiveness to filter the system properly.

3.) Fluid is re-circulated through a Fuller's Earth filter for acid correction as already mentioned. The Fuller's Earth media migrates and becomes part of the fluid contamination in the fluid. To eliminate this there is a Nugent filter (5 micron nominal) to remove this migrating media.

Filtration Upgrade Summary

We offer several options to meet your requirements and to assure that you get the best price for the filtration that is best for your components.

1.) a. Use the existing elements you have and clean and bubble test them through their useful life and then replace the four Cuno elements as needed on the power unit with **ALPHA** Grade 1SST high collapse rated filter element **model # S0060002**. These are the OEM stainless steel units that are cleanable.

(best alternative) or

b. Use the existing elements your have and clean and bubble test them through their useful life and then replace the four Cuno elements on the power unit with **ALPHA** Grade 1DS high collapse rated filter elements **model # S0030018**. These are also cleanable units.

(EQUAL or better alternative to OEM) and ..

c. Replace the remaining Cuno elements with **ALPHA** Grade 2 high collapse rated filter elements **model# S0010043**. These units are disposable.

(good alternative)

2.) a. Replace the 2 high stack LF-8 Schroeder housing with a single **ALPHA** Grade 1 **model # S0020021** filter housing. The elements for this housing are **model# S0020022**. Replace the three high stack with **ALPHA** Grade 1 **model# S0010041** filter elements. (See Table 2)

b. Replace the nine stacked Cuno elements with three **ALPHA** Grade 1 **model # S0060002** filter elements for optimum particulate polishing.

c. Replace the Nugent filter assembly with an **ALPHA** assembly Grade 1 **model # S0470003** filter elements to ensure that migrating particles are kept out of the control fluid.

Upgrade Table 2 ALPHA Model # Current Filter / model#

Element Location

High Pressure on HPU	S0060002	Cuno 52535-02-41-0104
Before Servovalve	S0060002	Cuno 52535-02-41-0104
Low Pressure Return	S0020022	Schroeder LF-8
Fuller's Earth	S0120001	Nugent Fuller's Earth
Polishing of Fuller's	S0470003	Nugent Polishing
Reservoir Breather	S0010042	PFD Filter Dryer

FILTERS (High and Low Pressure)

Transfer Filter Cart

This ServoCon ALPHA product is a bypass filter system transfer cart that offers constant flow at low pressure, while filtering system contaminants.

Using this system is an effective way to clean up system fluid that is transferred from barrels into your reservoir or by simply moving the fluid from a tank into a barrel and back repeatedly to remove contaminants. You may use a variety of elements including water absorption elements to remove moisture. The water removal elements can remove up to 15 fluid ounces per element. Fluid transfer using this cart may be done while the system is running.

There are flow capacities available in 5 and 11 gallons per minute using an industrial quality heavy duty gear pump and dual filters increasing dirt holding capacity for longer life. There is a "Y" strainer on the pump inlet with easy to change spin on filter elements that require no tools. This unit provides optimum fluid conditioning at a lower pressure and a steady flow rate. This cannot be accomplished on many other hydraulic and lubrication systems.

Elements available for this unit are 3, 10 and 25 micron. There is a built in by-pass valve with no partial by-pass until differential pressure (20psid) is reached. The unit requires a 115Volt AC, 10 amp, single phase 60 HZ power source through a 12 foot long cord having a standard 3 prong plug. There is an industrial toggle-operated motor starter mounted in a NEMA-1 enclosure with replaceable motor overloads.



Turbine Control Valves

Steam and Gas Turbine Controls

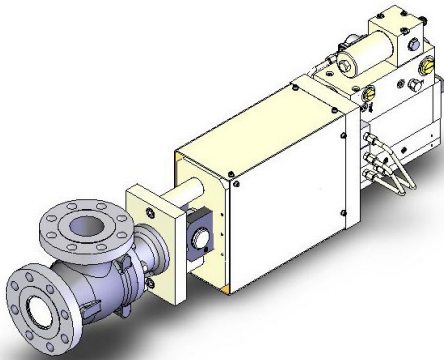

The Fuel Gas Control system is a two-stage system, incorporating a pressure control proportional to speed and a flow control proportional to fuel command for Frame 7FAgas turbines.

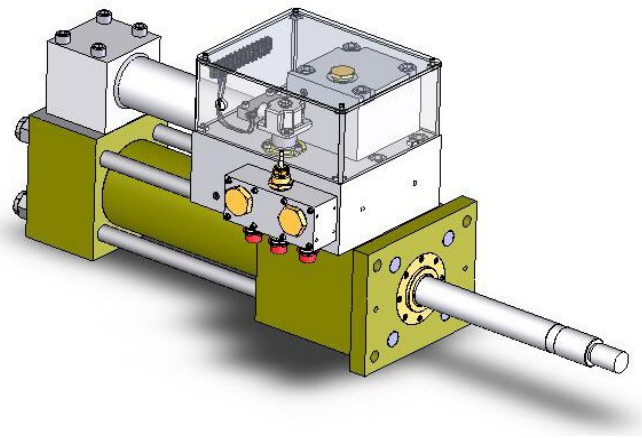

The Intercept Control System is used on the Large Steam generating units

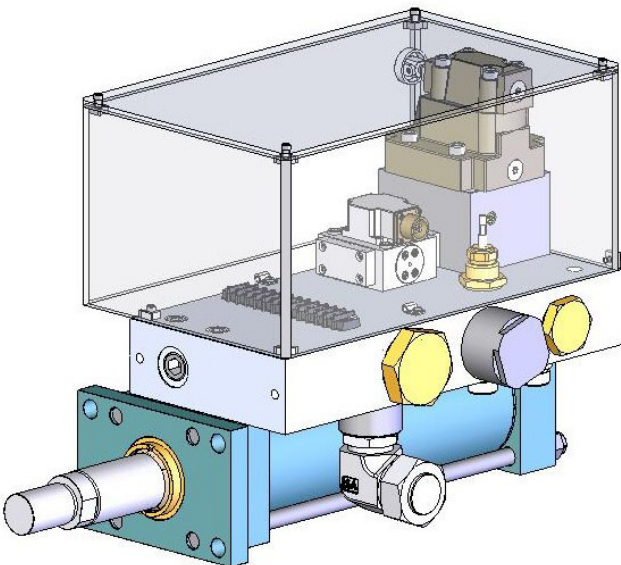

The Throttle Valve is used on the Large and Medium Steam generating units

Other Turbine Control Valves

Steam and Gas Turbine Controls

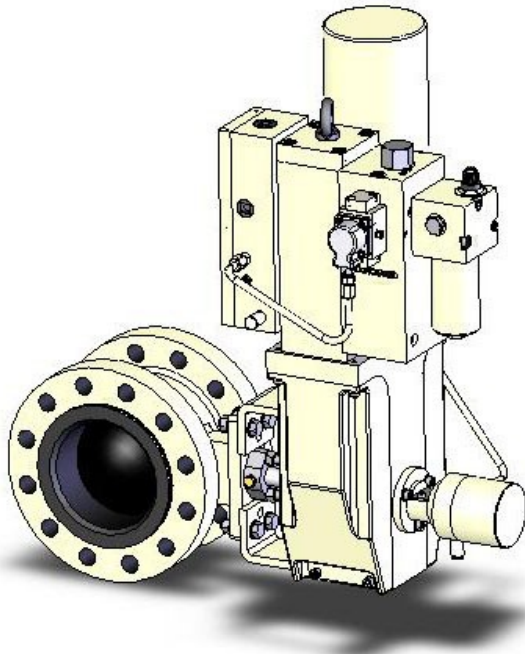

The Fuel Gas Stop Ratio Control system on Frame 7FA gas turbines.

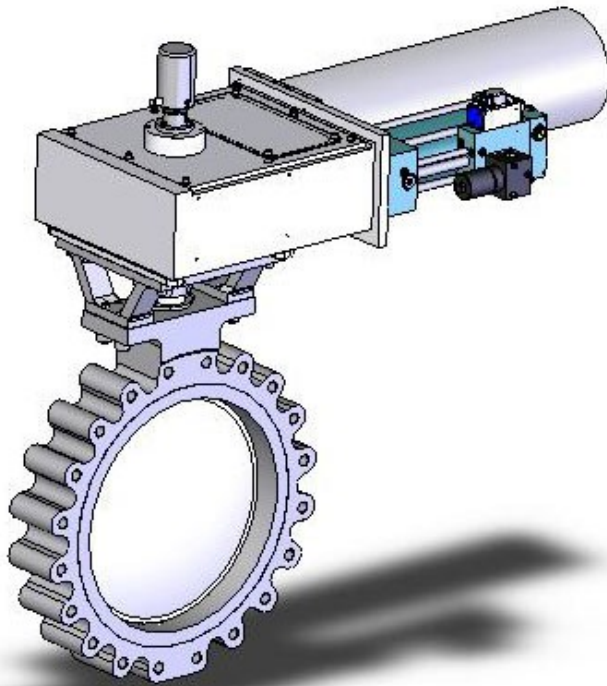

The LP Admission Steam Control system used on steam turbine Combined Cycle Units.

Other Products

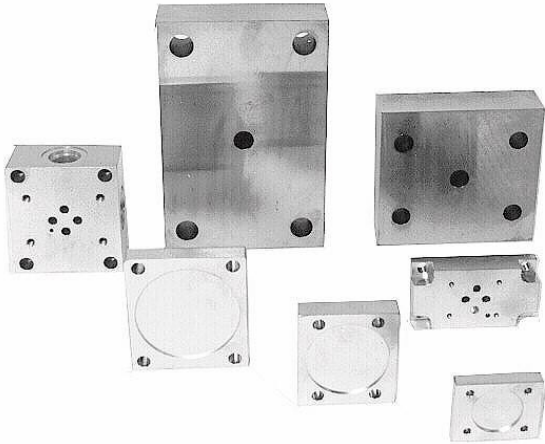

Manifolds, Adapters, Plates

We have manifolds for all valve types on Control Pacs, blanking plates and adapters for flushing valves and **retrofit servovalve** applications.



Flushing Valves

We can supply Flushing Valves to assist in cleaning up your Control Pac system. Available for all flow sizes and valve types.



Seals and Seal Kits

We provide seals, Orings and seal kits for servoactuators, cylinders, pumps and servovalves.

To Order Call: 1.800.447.7747

Other Products

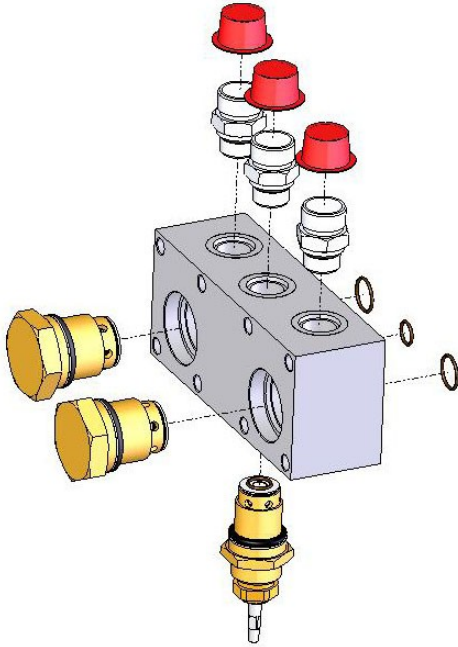

Manifolds, Fittings, Check Valves
like this interface manifold block
with an isolation shutoff valve

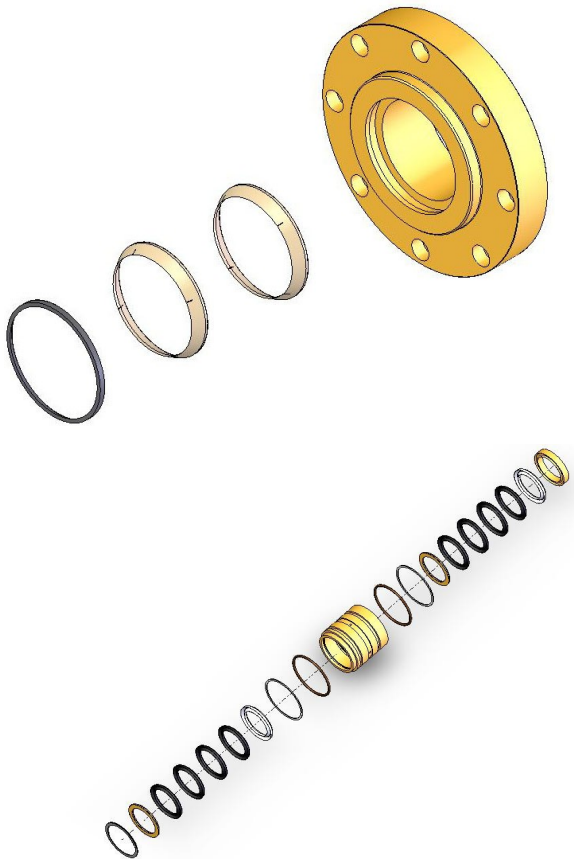

Glands and Seals for all
type actuator assemblies

ServoCon[®] ALPHA



ServoCon ALPHA

Expo Industrial Park

167 Expo Road

Fishersville, VA 22939

Phone: 800-447-7747

Fax: 540-337-4901

Email:

servoconalpha@servoconalpha.com

<http://www.servoconalpha.com>